



E I M A C

Division of Varian

SAN CARLOS

CALIFORNIA

8169

4CX3000A

**RADIAL-BEAM
POWER TETRODE**

The EIMAC 8169/4CX3000A is a ceramic and metal power tetrode designed to be used as a Class-AB₁ linear amplifier in audio or radio-frequency applications. Its characteristics of low intermodulation distortion make it especially suitable for single sideband service.

This tube is unique in that a production test is included to insure minimum distortion products. The 8169/4CX3000A must produce a *minimum* of 5300 watts in Class AB₁ service with IM distortion at least 32 db down, 3rd order.

The tube is also recommended for use as a Class-C radio-frequency power amplifier and plate-modulated radio-frequency power amplifier.



GENERAL CHARACTERISTICS

ELECTRICAL

| | | | | |
|------------------------------|-------------|-------------|-------------|-------|
| Filament: Thoriated Tungsten | <u>Min.</u> | <u>Nom.</u> | <u>Max.</u> | |
| Voltage - - - - | | 9.0 | | volts |
| Current - - - - | 39.5 | | 43.5 | amps |

Amplification Factor (Grid Screen) 5.5

Frequency For Maximum Ratings 150 MHz

Direct Interelectrode Capacitances, Grounded Cathode:

| | | | |
|------------------|------|------|----|
| Input - - - - | 120 | 140 | pF |
| Output - - - - | 10.5 | 14.5 | pF |
| Feedback - - - - | | 1.4 | pF |

Direct Interelectrode Capacitances, Grounded Grid and Screen:

| | | | |
|--|-------------|-------------|----|
| | <u>Min.</u> | <u>Max.</u> | |
| Input - - - - - - - - - - - - - - - - | 55 | 67 | pF |
| Output - - - - - - - - - - - - - - - - | 10.5 | 14.5 | pF |
| Feedback - - - - - - - - - - - - - - - - | | 0.2 | pF |

MECHANICAL

| | |
|--|--|
| Base - - - - - - - - - - - - - - - - | Special ring and breechblock terminal surfaces |
| Maximum Seal Temperature - - - - - - - - - - - - - - - - | 250°C |
| Maximum Anode Core Temperature - - - - - - - - - - - - - - - - | 250°C |
| Recommended Socket - - - - - - - - - - - - - - - - | EIMAC SK-1400 series |
| Recommended Air Chimney - - - - - - - - - - - - - - - - | EIMAC SK-1406 |
| Operating Position - - - - - - - - - - - - - - - - | Axis vertical, base up or down |
| Maximum Dimensions: | |
| Height - - - - - - - - - - - - - - - - | 7.9 inches |
| Diameter - - - - - - - - - - - - - - - - | 4.6 inches |
| Cooling - - - - - - - - - - - - - - - - | Forced air |
| Net Weight - - - - - - - - - - - - - - - - | 5.5 pounds |
| Shipping Weight (Approximate) - - - - - - - - - - - - - - - - | 10 pounds |

RADIO-FREQUENCY POWER AMPLIFIER OR OSCILLATOR

Class-C Telegraphy or FM Telephony
(Key-down conditions)

MAXIMUM RATINGS

| | | | | |
|--------------------|---|---|---|------------|
| DC PLATE VOLTAGE | - | - | - | 7000 VOLTS |
| DC SCREEN VOLTAGE | - | - | - | 1000 VOLTS |
| DC PLATE CURRENT | - | - | - | 2.0 AMPS |
| PLATE DISSIPATION | - | - | - | 3000 WATTS |
| SCREEN DISSIPATION | - | - | - | 175 WATTS |
| GRID DISSIPATION | - | - | - | 50 WATTS |

TYPICAL OPERATION

| | | | | | |
|----------------------|---|---|---|------|--------------|
| DC Plate Voltage | - | - | - | 5000 | 7000 volts |
| DC Screen Voltage | - | - | - | 500 | 500 volts |
| DC Grid Voltage | - | - | - | -280 | -300 volts |
| DC Plate Current | - | - | - | 1.9 | 1.9 amps |
| DC Screen Current | - | - | - | 250 | 230 mA |
| DC Grid Current | - | - | - | 100 | 100 mA |
| Peak RF Grid Voltage | - | - | - | 385 | 405 volts |
| Driving Power | - | - | - | 39 | 41 watts |
| Plate Dissipation | - | - | - | 1900 | 2300 watts |
| Plate Output Power | - | - | - | 7600 | 11,000 watts |

PLATE-MODULATED RADIO-FREQUENCY POWER AMPLIFIER

Class-C Telephony (Carrier Conditions unless noted)

MAXIMUM RATINGS

| | | | | |
|--------------------|---|---|---|------------|
| DC PLATE VOLTAGE | - | - | - | 5000 VOLTS |
| DC SCREEN VOLTAGE | - | - | - | 600 VOLTS |
| DC PLATE CURRENT | - | - | - | 1.4 AMPS |
| PLATE DISSIPATION* | - | - | - | 2000 WATTS |
| SCREEN DISSIPATION | - | - | - | 175 WATTS |
| GRID DISSIPATION | - | - | - | 50 WATTS |

*Corresponds to 3000 watts at 100 percent sine-wave modulation.

TYPICAL OPERATION

| | | | | |
|------------------------|---|---|---|------------|
| DC Plate Voltage | - | - | - | 5000 volts |
| DC Screen Voltage | - | - | - | 500 volts |
| Peak AF Screen Voltage | - | - | - | |
| (For 100% Modulation) | - | - | - | 415 volts |
| DC Grid Voltage | - | - | - | -375 volts |
| DC Plate Current | - | - | - | 1.4 amps |
| DC Screen Current | - | - | - | 170 mA |
| DC Grid Current | - | - | - | 68 mA |
| Peak RF Grid Voltage | - | - | - | 455 volts |
| Grid Driving Power | - | - | - | 31 watts |
| Plate Dissipation | - | - | - | 1250 watts |
| Plate Output Power | - | - | - | 5750 watts |

AUDIO-FREQUENCY AMPLIFIER OR MODULATOR

Class-AB

MAXIMUM RATINGS (Per Tube)

| | | | | |
|--------------------|---|---|---|------------|
| DC PLATE VOLTAGE | - | - | - | 6000 VOLTS |
| DC SCREEN VOLTAGE | - | - | - | 1000 VOLTS |
| DC PLATE CURRENT | - | - | - | 2.0 AMPS |
| PLATE DISSIPATION | - | - | - | 3500 WATTS |
| SCREEN DISSIPATION | - | - | - | 175 WATTS |
| GRID DISSIPATION | - | - | - | 50 WATTS |

*Per tube

**Approximate values

TYPICAL OPERATION (Two Tubes), Class AB₁

| | | | | | |
|---------------------------------|---|---|---|--------|--------------|
| DC Plate Voltage | - | - | - | 5000 | 6000 volts |
| DC Screen Voltage | - | - | - | 850 | 850 volts |
| DC Grid Voltage* | - | - | - | -180 | -200 volts |
| Max-Signal Plate Current | - | - | - | 3.6 | 3.1 amps |
| Zero-Signal Plate Current | - | - | - | 1.0 | 0.7 amp |
| Max-Signal Screen Current** | - | - | - | 170 | 120 mA |
| Zero-Signal Screen Current | - | - | - | 0 | 0 mA |
| Peak AF Driving Voltage* | - | - | - | 155 | 175 volts |
| Driving Power | - | - | - | 0 | 0 watts |
| Load Resistance, Plate-to-Plate | - | - | - | 3000 | 4160 ohms |
| Max-Signal Plate Dissipation* | - | - | - | 3300 | 3100 watts |
| Max-Signal Plate Output Power | - | - | - | 11,400 | 12,400 watts |

NOTE: In Class AB operation, maximum plate voltage and plate current must not be applied simultaneously, as plate dissipation will be exceeded.

RADIO-FREQUENCY LINEAR AMPLIFIER

Class-AB

MAXIMUM RATINGS

| | | | | |
|--------------------|---|---|---|------------|
| DC PLATE VOLTAGE | - | - | - | 6000 VOLTS |
| DC SCREEN VOLTAGE | - | - | - | 1000 VOLTS |
| DC PLATE CURRENT | - | - | - | 2.0 AMPS |
| PLATE DISSIPATION | - | - | - | 3500 WATTS |
| SCREEN DISSIPATION | - | - | - | 175 WATTS |
| GRID DISSIPATION | - | - | - | 50 WATTS |

*Approximate values

These values are obtained in existing equipment. A design test is performed on a sampling basis, insuring that the 4CX3000A will perform as indicated with respect to IM distortion products and power output.

TYPICAL OPERATION Class AB₁, Grid Driven

| | | | | |
|-------------------------------------|---|---|---|------------|
| DC Plate Voltage | - | - | - | 5000 volts |
| DC Screen Voltage | - | - | - | 850 volts |
| DC Grid Voltage* | - | - | - | 180 volts |
| Zero-Signal DC Plate Current | - | - | - | 0.5 amp |
| Single-Tone DC Plate Current | - | - | - | 1.65 amps |
| Single-Tone DC Screen Current | - | - | - | 25 mA |
| Two-Tone DC Plate Current | - | - | - | 1.10 amps |
| Two-Tone DC Screen Current | - | - | - | 20 mA |
| Peak RF Grid Voltage | - | - | - | 155 volts |
| Driving Power | - | - | - | 0 watts |
| Peak Envelope Useful Output Power | - | - | - | 5300 watts |
| Resonant Load Impedance | - | - | - | 1700 ohms |
| Intermodulation Distortion Products | - | - | - | |
| (without negative feedback) | - | - | - | -32 db |

NOTE: "TYPICAL OPERATION" data are obtained by calculation from published characteristic curves and confirmed by direct tests. No allowance is made for circuit losses. Adjustment of the rf grid drive to obtain the specified plate current at the specified grid bias, screen voltage, and plate voltage is assumed.



APPLICATION

MECHANICAL

Mounting — The 4CX3000A must be operated with its axis vertical. The base of the tube may be down or up at the convenience of the circuit designer.

Socket — The EIMAC SK-1400A and SK-1470A sockets have been designed especially for the 4CX3000A. The use of recommended air-flow rates through these sockets provides effective forced-air cooling of the tube. Air forced into the bottom of the socket passes over the tube terminals through an Air Chimney, the SK-1406, and through the anode cooling fins.

Cooling — The maximum temperature rating for the external surfaces of the 4CX3000A is 250°C. Sufficient forced-air circulation must be provided to keep the temperature of the anode at the base of the cooling fins and the temperature of the ceramic-metal seals below 250°C. Air-flow requirements to maintain seal temperature at 200°C in 40°C ambient air are tabulated below (for operation below 30 megahertz).

| Plate Dissipation* (Watts) | SEA LEVEL | | 10,000 FEET | |
|----------------------------|----------------|---------------------------------|----------------|---------------------------------|
| | Air Flow (CFM) | Pressure Drop (Inches of water) | Air Flow (CFM) | Pressure Drop (inches of water) |
| 1500 | 36.5 | 0.3 | 53 | 0.4 |
| 2500 | 60 | 0.8 | 88 | 1.2 |
| 3500 | 86 | 1.6 | 125 | 2.3 |

*Since the power dissipated by the filament represents about 450 watts and since grid-plus-screen dissipation can, under some conditions, represent another 225 watts, allowance has been made in preparing this tabulation for an additional 675 watts dissipation.

The blower selected in a given application must be capable of supplying the desired air flow at a back pressure equal to the pressure drop shown above plus any drop encountered in ducts and filters.

At other altitudes and ambient temperatures the flow rate must be modified to obtain equivalent cooling. The flow rate and corresponding pressure differential must be determined individually in such cases, using rated maximum temperatures as the criteria for satisfactory cooling.

ELECTRICAL

Filament Operation—The rated filament voltage for the 4CX3000A is 9.0 volts. Filament voltage, as measured at the socket, should be maintained at this value to obtain maximum tube life. In no case should it be allowed to deviate by more than plus or minus five percent from the rated value.

Intermodulation Distortion — The operating conditions including distortion data are the results of actual operation in a neutralized, grid-driven amplifier. This test is performed on sample tubes from regular production runs. A plot of IM distortion versus power output under two-tone condition for a typical tube is shown on the next page.

Control Grid Operation — The rated dissipation of the grid is 50 watts. This is approximately the product of dc grid current and peak positive grid voltage. Operation at bias and drive levels near those listed will insure safe operation.

Screen-Grid Operation — The power dissipated by the screen of the 4CX3000A must not exceed 175 watts.

Screen dissipation, in cases where there is no ac applied to the screen, is the simple product of the screen voltage and the screen current. If the screen voltage is modulated, the screen dissipation will depend upon loading, driving power, and carrier screen voltage.

Screen dissipation is likely to rise to excessive values when the plate voltage, bias voltage, or plate load are removed with filament and screen voltages applied. Suitable protective means must be provided to limit the screen dissipation to 175 watts in the event of circuit failure.

Plate Dissipation—The plate-dissipation ratings for the 4CX3000A are 2000 watts for Class-C plate-modulated service and 3000 watts for Class-C telegraphy. In Class-AB operation this rating has been increased to 3500 watts to allow more input. In any Class-AB application maximum plate current and maximum plate voltage should not be applied simultaneously as the plate-dissipation rating would be exceeded.

Special Applications—If it is desired to operate this tube under conditions widely different from those given here, write to the Power Grid Tube Division or Product Manager, EIMAC Division of Varian, 301 Industrial Way, San Carlos, California, for information and recommendations.

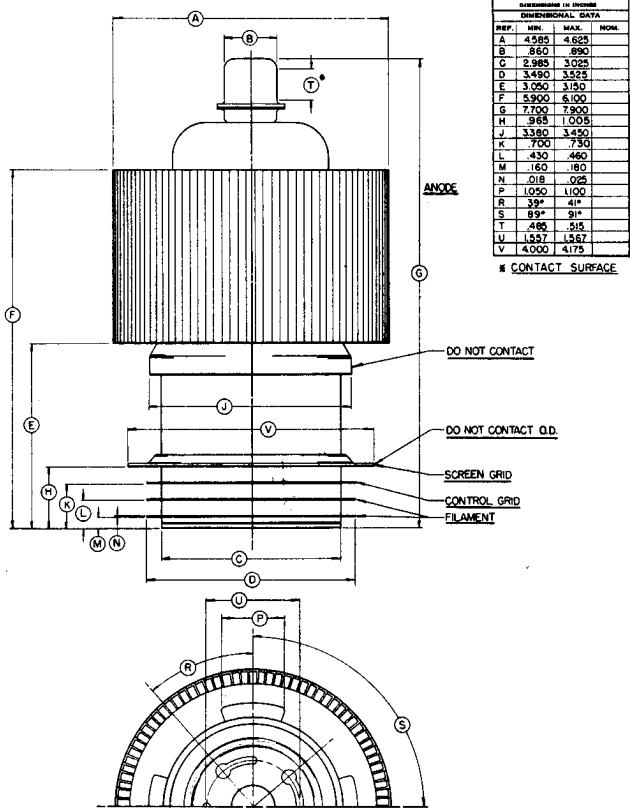
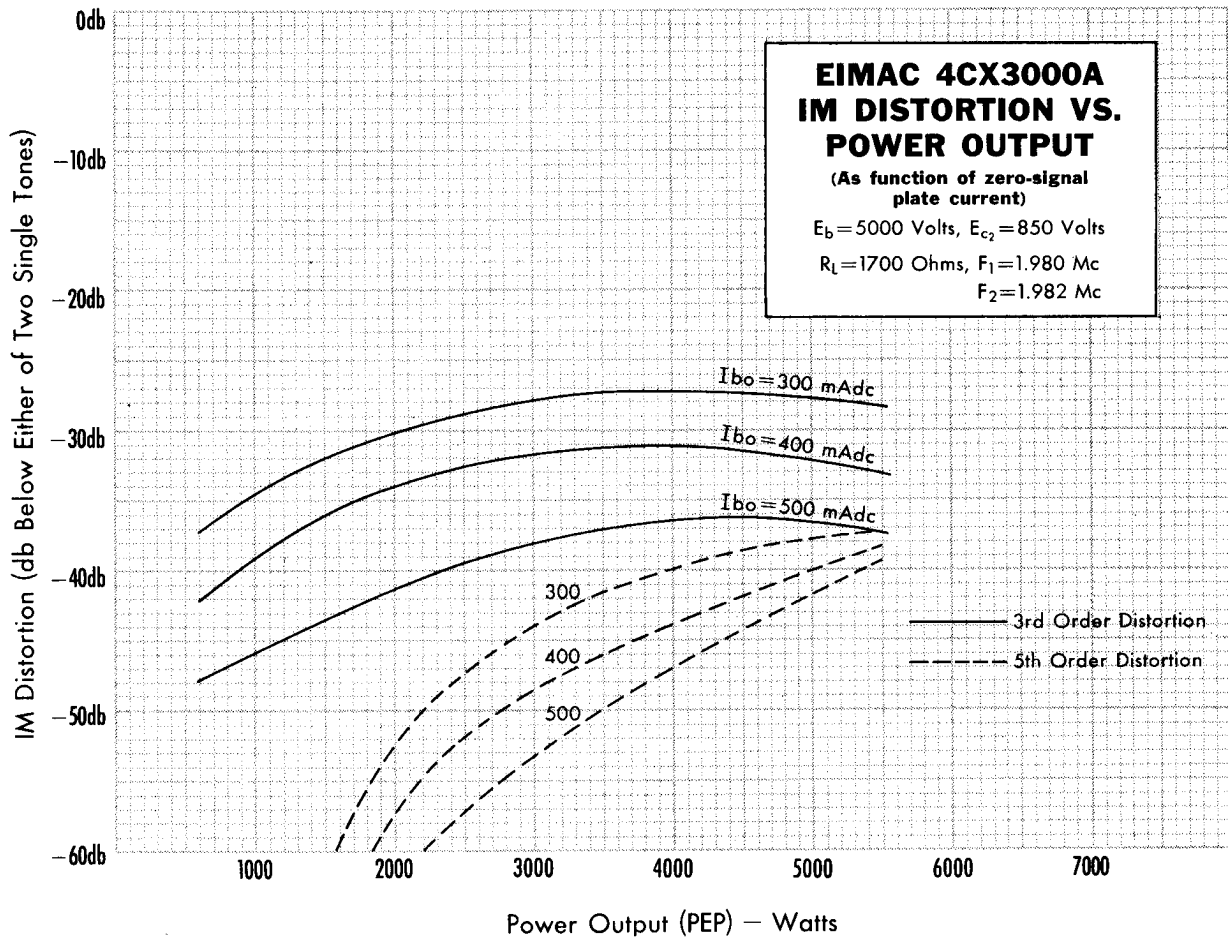



EIMAC 4CX3000A TYPICAL CONSTANT CURRENT CHARACTERISTICS

SCREEN VOLTAGE = 850 VOLTS
— PLATE CURRENT — AMPERES
- - - SCREEN CURRENT — AMPERES
- - - GRID CURRENT — AMPERES

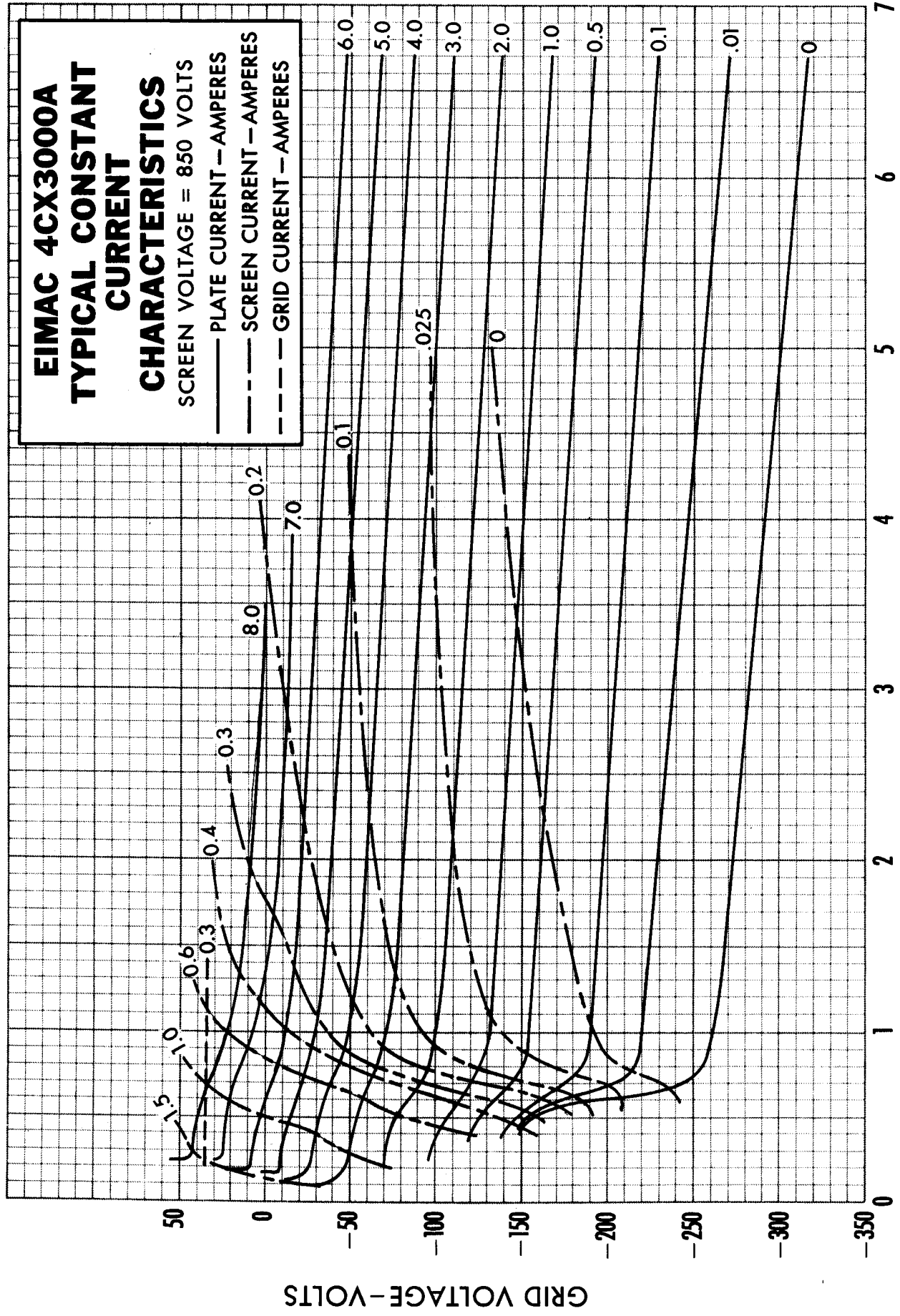

PLATE VOLTAGE—KILOVOLTS



EIMAC 4CX3000A TYPICAL CONSTANT CURRENT CHARACTERISTICS

SCREEN VOLTAGE = 500 VOLTS

- PLATE CURRENT — AMPERES
- - - SCREEN CURRENT — AMPERES
- - - - GRID CURRENT — AMPERES

